

KINCHI- GODVHEN



Material : Aluminum die-cast housing.

IP Class : IP20

Suitable Operating Ambient Temperature : $-20^{\circ}\text{C} < t_a < + 45^{\circ}\text{C}$

Atex Certificate : CE -EN-IEC 60598-1-EN IEC 60598-2-1

Cable Gland Entries : Trifaze/monofaze soket

Led : LEDVANCE/TYF/PHILIPS

Power Options : 5W/7W/10W

Driver : LIFUT/EAGLERISE/OSRAM ELEMENT

Suitable Operating Voltage Range : 220-240V

Frequency Range : 50-60 Hz

Paint : Electrostatic Powder Coating

Mounting Accessories : TRIFAZE/MONOFAZE RAY

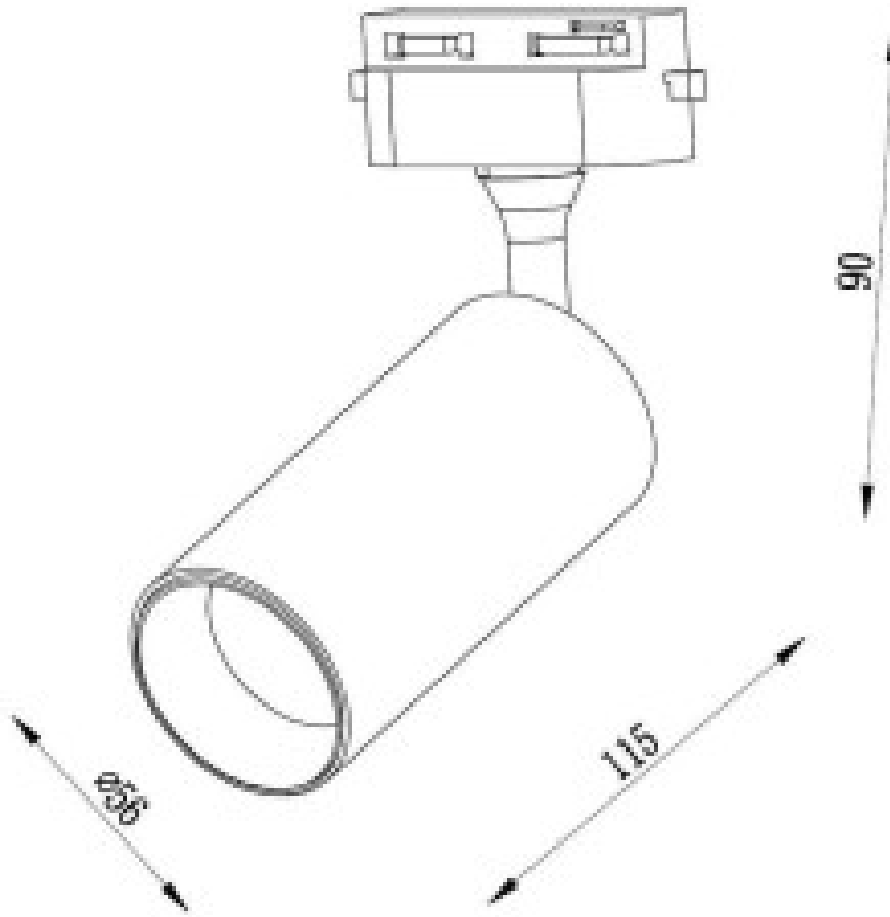

| CODE | POWER | DIMENSIONS | LUMEN | KELVIN | MOUNTING CUT-OUT SIZE | CRI | WEIGHT |
|----------------|-------|------------|-------|----------------|-----------------------|--------|--------|
| KINCHI-GODVHEN | 5W | 115/70 | 700 | 4000/5000/3000 | - | CRI>95 | 0,5 kg |
| KINCHI-GODVHEN | 7W | 115/70 | 980 | 4000/5000/3000 | - | CRI>95 | 0,5 kg |
| KINCHI-GODVHEN | 10W | 115/70 | 1400 | 4000/5000/3000 | - | CRI>95 | 0,5 kg |